

Discovery kit with STM32WB5MMG module

Introduction

The STM32WB5MM-DK Discovery kit is designed as a complete demonstration and development platform for the STMicroelectronics STM32WB5MMG module based on the Arm® Cortex®-M4 and Arm® Cortex®-M0+ cores.

The STM32 device is a multiprotocol wireless and ultra-low-power device embedding a powerful and ultra-low-power radio compliant with the Bluetooth® Low Energy SIG specification v5.4 and IEEE 802.15.4-2011.

The hardware features of the Discovery kits are available for users to develop their applications: Audio, USB, user buttons, and Bluetooth® Low Energy. Extension connectors allow easy connection of an ARDUINO® board for a specific application.

ST-LINK/V2-1 is integrated on the board, as an embedded in-circuit debugger and programmer for the STM32 MCU and the USB Virtual COM port bridge.

Figure 1. STM32WB5MM-DK Discovery kit

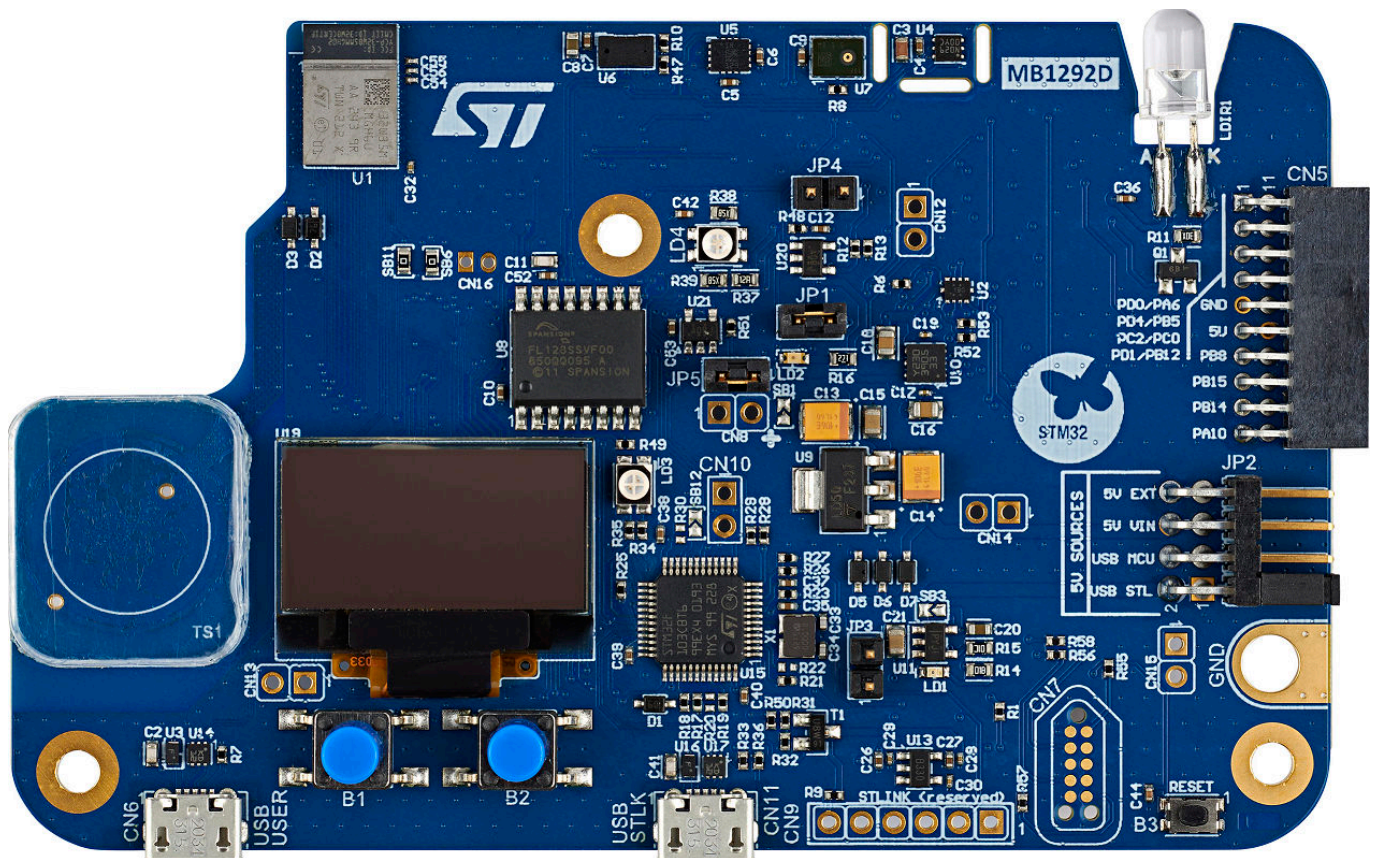

Picture is not contractual.

1 Features

- STM32WB5MMG (1-Mbyte flash memory, 256-Kbyte SRAM, in module RF package)
 - Dual-core 32-bit (Arm® Cortex®-M4 and dedicated M0+ CPU for real-time radio layer)
 - 2.4 GHz RF transceiver supporting Bluetooth® specification V5.4, 802.15.4 with Zigbee®, Thread®, and proprietary protocols
- 0.96-inch 128×64 OLED display
- 128-Mbit Quad-SPI NOR flash memory
- Temperature sensor
- Accelerometer-gyroscope sensor
- Time-of-Flight and gesture-detection sensor
- Digital microphone
- RGB LED
- Infrared LED
- Three push-buttons (two users and one reset) and one touchkey button
- Board connectors:
 - STMod+
 - ARDUINO® Uno V3 expansion connector
 - USB user with Micro-B connector
 - TAG10 10-pin footprint
- Flexible power supply options: ST-LINK/V2-1 USB connector, 5 V delivered by ARDUINO® or external connector, USB charger, or USB power
- On-board ST-LINK/V2-1 debugger/programmer with USB re-enumeration capability: Virtual COM port and debug port
- Comprehensive free software libraries and examples available with the [STM32CubeWB](#) MCU Package
- Support of a wide choice of Integrated Development Environments (IDEs) including IAR Embedded Workbench®, MDK-ARM, and STM32CubeIDE

Note: For information on Bluetooth®, refer to the www.bluetooth.com website

Note: Arm is a registered trademark of Arm Limited (or its subsidiaries) in the US and/or elsewhere.



2 Ordering information

To order the STM32WB5MM-DK Discovery kit, refer to [Table 1](#). Additional information is available from the datasheet and reference manual of the target STM32.

Table 1. Ordering information

Order code	Board reference	Target STM32
STM32WB5MM-DK	MB1292 ⁽¹⁾	STM32WB5MMG

1. Subsequently called main board in the rest of the documentation.

2.1 Codification

The meaning of the codification is explained in [Table 2](#).

Table 2. Codification explanation

STM32XXYYM-DK	Description	Example: STM32WB5MM-DK
XX	MCU series in STM32 32-bit Arm Cortex MCUs	STM32WB series
YY	MCU product line in the series	STM32WBxM Modules line (5M module version)
DK	Discovery kit	Discovery kit

3 Development environment

3.1 System requirements

- Multi-OS support: Windows® 10, Linux® 64-bit, or macOS®
- USB Type-A or USB Type-C® to Micro-B cable

Note: macOS® is a trademark of Apple Inc., registered in the U.S. and other countries and regions.
Linux® is a registered trademark of Linus Torvalds.
Windows is a trademark of the Microsoft group of companies.

3.2 Development toolchains

- IAR Systems® - IAR Embedded Workbench®⁽¹⁾
- Keil® - MDK-ARM⁽¹⁾
- STMicroelectronics - STM32CubeIDE

1. On Windows® only.

3.3 Demonstration software

The demonstration software, included in the STM32Cube MCU Package corresponding to the on-board microcontroller, is preloaded in the STM32 flash memory for easy demonstration of the device peripherals in standalone mode. The latest versions of the demonstration source code and associated documentation can be downloaded from www.st.com.

4 Conventions

Table 3 provides the conventions used for the ON and OFF settings in the present document.

Table 3. ON/OFF convention

Convention	Definition
Jumper JPx ON	Jumper fitted
Jumper JPx OFF	Jumper not fitted
Jumper JPx [1-2]	Jumper fitted between Pin 1 and Pin 2
Solder bridge SBx ON	SBx connections closed by 0 Ω resistor
Solder bridge SBx OFF	SBx connections left open
Resistor Rx ON	Resistor soldered
Resistor Rx OFF	Resistor not soldered
Capacitor Cx ON	Capacitor soldered
Capacitor Cx OFF	Capacitor not soldered

5 Safety recommendations

5.1 Targeted audience

This product targets users with at least basic electronics or embedded software development knowledge like engineers, technicians, or students.

This board is not a toy and is not suited for use by children.

5.2 Handling the board

This product contains a bare printed circuit board and as with all products of this type, the user must be careful about the following points:

- The connection pins on the board might be sharp. Be careful when handling the board to avoid hurting yourself.
- This board contains static-sensitive devices. To avoid damaging it, handle the board in an ESD-proof environment.
- While powered, do not touch the electric connections on the board with fingers or anything conductive. The board operates at a voltage level that is not dangerous, but components might be damaged when shorted.
- Do not put any liquid on the board. Avoid operating the board close to water or at a high humidity level.
- Do not operate the board if dirty or dusty.

5.3 Laser safety consideration

The Time-of-Flight and gesture-detection sensor contains a laser emitter and the corresponding drive circuitry. The laser output is designed to remain within Class 1 laser safety limits under all reasonably foreseeable conditions including single faults in compliance with IEC 60825-1:2014 (third edition). The laser output remains within Class 1 limits as long as the STMicroelectronics recommended device settings are used and the operating conditions specified in the STM32WB datasheets are respected. The laser output power must not be increased by any means and no optics are used to focus the laser beam. [Figure 2](#) shows the warning label for Class 1 laser products.

Figure 2. Class 1 laser product label



6 Getting started

This section describes how to start quickly development using the STM32WB5MM-DK Discovery kit.

To use the product, the user must accept the evaluation product license agreement from the www.st.com/epla webpage.

Before the first use, make sure that no damage occurred to the board during shipment:

- All socketed components are firmly secured in their sockets.
- No component is loose in the board blister.

The Discovery kit is an easy-to-use Discovery kit to evaluate and start quickly development with an STM32 microcontroller in an RF module package:

1. Check jumper positions on board: JP1 and JP5 ON, JP2 (power source) on USB MCU.
2. Install ST Bluetooth® Low Energy sensor mobile application on a Bluetooth® Low Energy-compatible mobile device from the App Store or Google Play.
3. On the host PC, any freeware or commercial audio recording software can be used to interface with the Discovery board. For example, Audacity® is an open-source, cross-platform program for recording and audio editing, available from <https://www.audacityteam.org/download>.
4. Connect the Discovery board to a PC with a USB Type-A to Micro-B cable through the USB USER connector (CN6). Windows automatically recognizes the board as a standard microphone (found in the *Windows device manager* as an STM32 audio streaming in FS mode). As soon as *BLE Advertising* appears on the Discovery display, the board is ready to connect.
5. Use the ST Bluetooth® Low Energy sensor mobile application to detect the STM32WB5MM-DK (BVL-WB1) with ST Bluetooth® 00:80:E1:26:XX:XX device address and connect to it. The text *BLE Connected* appears on the Discovery board display, while the BlueVoice FullDuplex page is shown on the mobile application.
6. Pushing the B1 button on the board starts the audio acquisition and streaming from the Discovery on the application (*Audio TX* on the display). Audio can be heard from the smartphone speaker.
7. Enabling the *Start* switch on the App starts audio streaming from the smartphone to the Discovery (*Audio RX* on the display). Open Audacity on the host PC. To start an audio recording, check first if the audio input device is *STM32 AUDIO streaming* and then press the recording button. To listen to the received audio while recording, go to *Edit* > *Preferences* > *Recording* and check the *Software playthrough of input*.
8. A full-duplex communication is performed if the streaming is enabled on both sides. *Full-duplex* message appears on the Discovery display.
9. For more details, refer to the user manual *Getting started with the STM32Cube function pack for STM32WB MCU featuring advanced audio streaming over Bluetooth 5.0 using Opus codec (UM2614)* of FP-AUD-BVLINKWB1, together with the demonstration software version v.2.0.0 or higher.

7 Hardware layout and configuration

The STM32WB5MM-DK Discovery kit is designed around the STM32WB5MMG RF module that includes an STM32WB55VG Bluetooth® Low Energy microcontroller, a ceramic antenna, two crystals, and peripheral components. The hardware block diagram in [Figure 3](#) illustrates the connections between the STM32WB5MMG RF module and the peripheral components (Quad-SPI flash memory, OLED display, USB OTG HS and FS connectors, USART, audio, ARDUINO® Uno V3, STMod+ shields, and embedded ST-LINK). [Figure 4](#) and [Figure 5](#) show the location of the main components on both sides of the Discovery board. [Figure 6](#) shows the STM32WB5MM-DK board mechanical dimensions.

Figure 3. STM32WB5MM-DK hardware block diagram

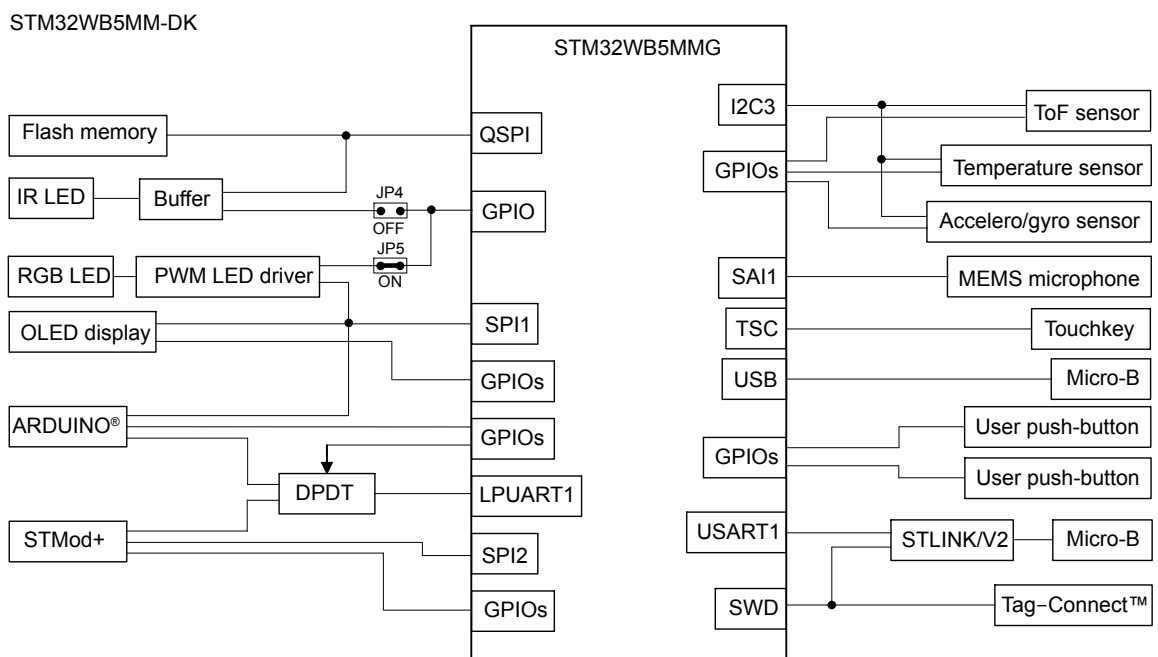

DT54483V2

Figure 4. STM32WB5MM-DK PCB layout (top view)

Figure 5. STM32WB5MM-DK PCB layout (bottom view)

Figure 6. STM32WB5MM-DK board mechanical dimensions (top view, in millimeters)

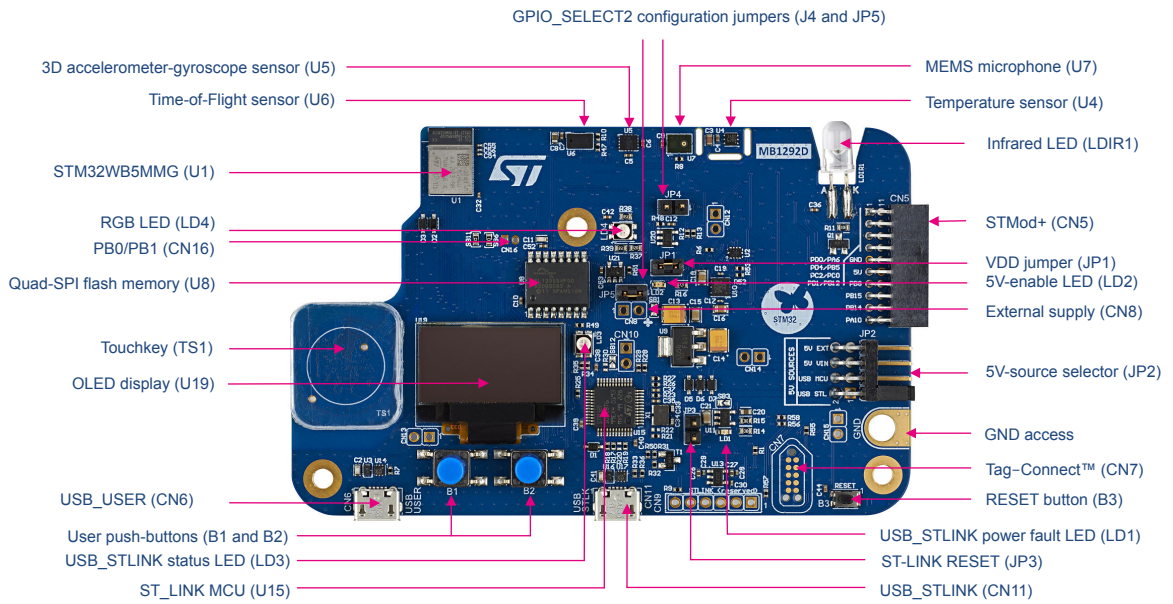
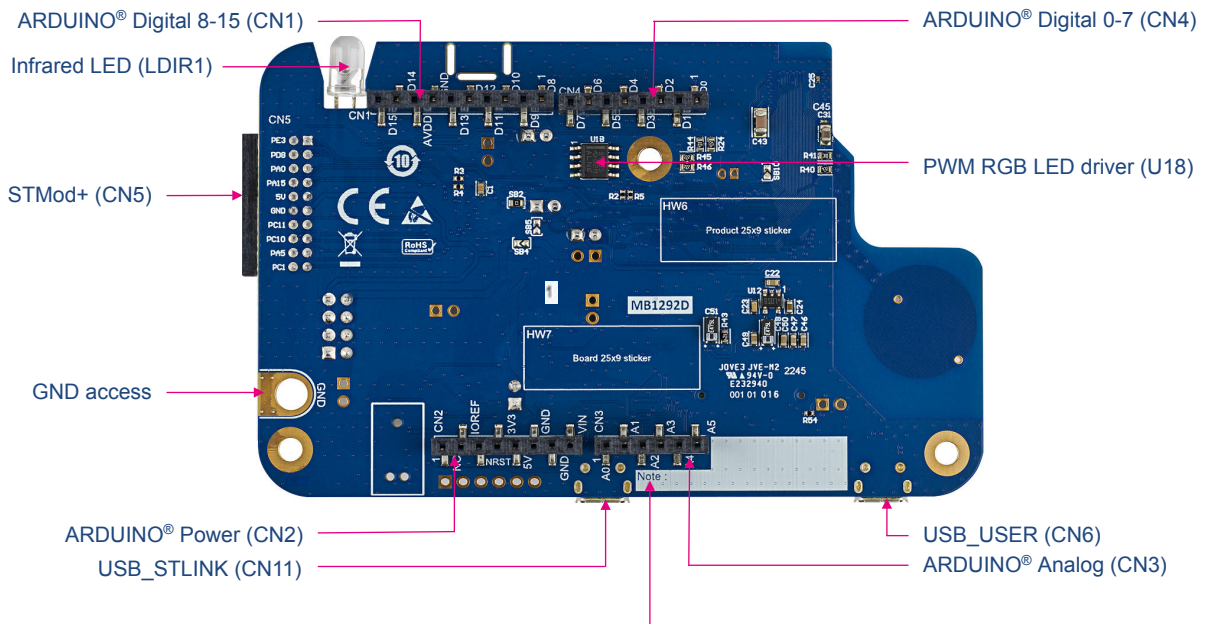
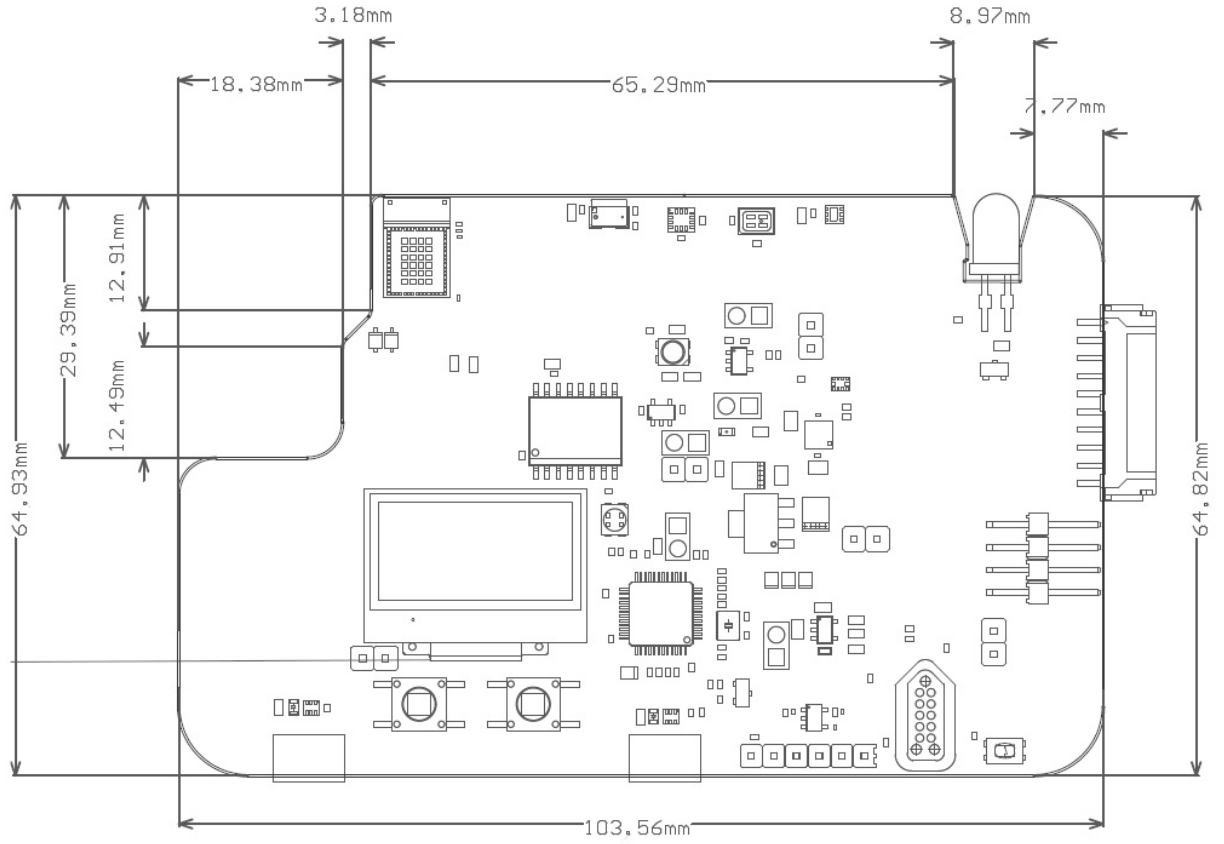

7.1 Embedded ST-LINK/V2-1

The ST-LINK/V2-1 programming and debugging tool is integrated into the STM32WB5MM-DK Discovery kit. For information about debugging and programming features refer to the user manual *ST-LINK/V2 in-circuit debugger/programmer for STM8 and STM32 (UM1075)*, which describes in detail all the ST-LINK/V2 features.

The additional features supported on the ST-LINK/V2-1 are:

- USB software re-enumeration
- Virtual COM port interface on USB
- Mass storage interface on USB
- USB power management request for more than 100 mA current on USB (limited to 300 mA for this board)

The following feature is no longer supported on the ST-LINK/V2-1:

- Application voltage lower than 3 V

7.1.1 Drivers

The ST-LINK/V2-1 requires a dedicated USB driver, which, for Windows® 7 and Windows® 8, is found at www.st.com. For Windows® 10 and Windows® 11, it is not necessary to install the driver, as the ST-LINK is automatically identified.

In case the STM32WB5MM-DK Discovery kit is connected to the PC before the driver is installed, some Discovery board interfaces might be declared as *Unknown* in the PC device manager. In this case, the user must install the dedicated driver files, and update the driver of the connected device from the device manager as shown in [Figure 7](#).

Note: Prefer using the USB Composite Device handle for a full recovery.

Figure 7. USB Composite Device

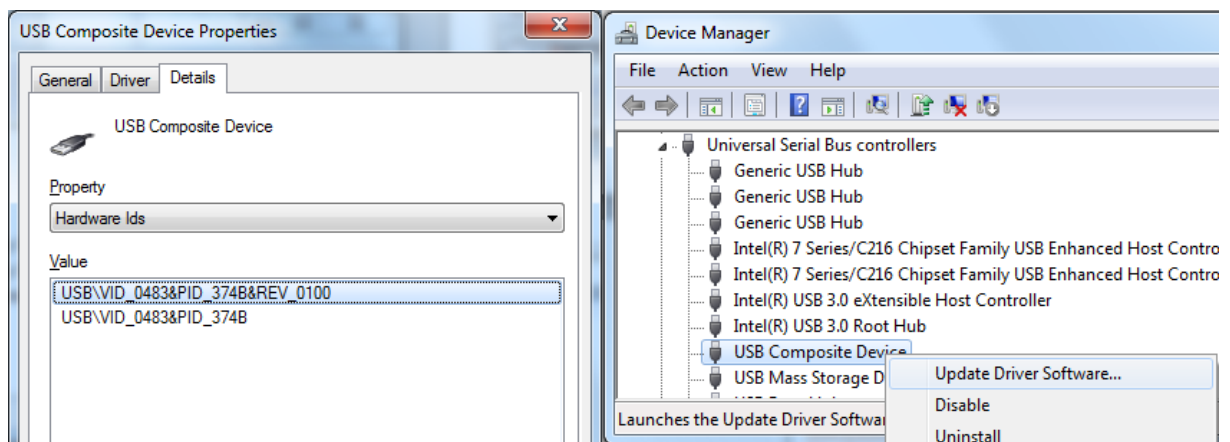

7.1.2 ST-LINK/V2-1 firmware upgrade

The ST-LINK/V2-1 embeds a firmware upgrade mechanism for the in-place upgrade through the USB port. As the firmware might evolve during the lifetime of the ST-LINK/V2-1 product (for example new functionalities, bug fixes, support for new microcontroller families), it is recommended to visit the www.st.com website before starting to use the STM32WB5MM-DK Discovery kit and periodically, to stay up-to-date with the latest firmware version.

7.2 Power supply

7.2.1 General description

The STM32WB5MMG module embedded in this STM32WB5MM-DK Discovery kit is always supplied by 3V3 but the board proposes a lot of possibilities to supply the module. The supply source can come from USB or ARDUINO® connectors, or from an external power supply. Figure 8 describes the board power tree. Moreover, this figure also shows the default state of the jumpers and solder bridges.

Figure 8. STM32WB5MM-DK power tree

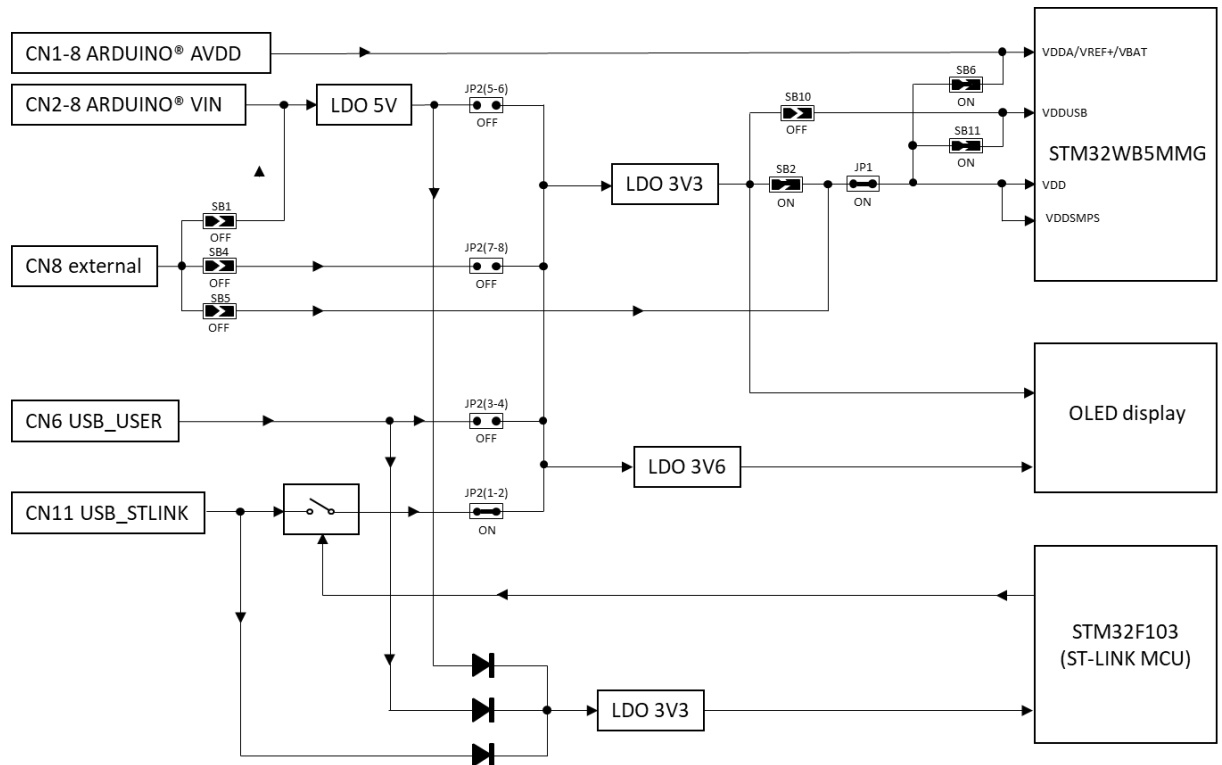

7.2.2 7 to 12 V power supply

The STM32WB5MM-DK Discovery kit can be powered with a 7 to 12 V DC power source. There are two accesses for this type of level:

- VIN pin of the ARDUINO® connector (CN2-8). It is possible to apply until +12 V on this pin or use an ARDUINO® shield, which can deliver this type of voltage on the VIN pin.
- External input (CN8).

Caution: In this case, paying attention to the configuration of the jumpers and solder bridges is very important. Verify this configuration in Table 4.

These two sources are connected to a linear low-drop voltage regulator (U9). The 5 V output of this regulator is a potential source of the 5V signal. Refer to Section 7.2.3 for the details.

7.2.3 5 V power supply

A 5 V DC power source can power the STM32WB5MM-DK Discovery kit. The 5V signal can come from several connectors:

- 5V_USB_STLK connected to CN11 (default configuration for the supply of the board). This connector is dedicated to accessing the ST-LINK/V2 and the Virtual COM port and can supply power from the host computer. It is also possible to connect a USB charger to this connector. In this case, the ST-LINK and the Virtual COM port cannot be accessible.
- 5V_USB_MCU connected to the user USB. This USB port is directly connected to the STM32WB5MMG as a USB port. The same remark applies to 5V_USB-STLK. The host computer or a USB charger can provide the supply.
- External input (CN8). Be careful, in this case, the state of the jumpers and the solder bridges is very important. Refer to [Section 7.2.2](#) for details.
- 7-12 V input through the U9 voltage regulator. Refer to [Section 7.2.2](#) for details.

The JP2 jumper JP2 selects the 5V source. [Table 4](#) shows the configuration for the selected source.

Caution: Depending on the current needed on the devices connected to the USB port, and the board itself, power limitations can prevent the system from working as expected. The user must ensure that the STM32WB5MM-DK Discovery kit is supplied with an adequate power source depending on the needed current.

Table 4. JP2 power supply selector description

Jumper/solder bridge	Setting	Configuration ⁽¹⁾
JP2 5 V supply source selector		STM32WB5MM-DK is supplied through the USB_STLINK Micro-B USB receptacle (CN11).
		STM32WB5MM-DK is supplied through the USB_USER Micro-B receptacle (CN6).
		STM32WB5MM-DK is supplied through ARDUINO® (CN2-8) or CN8 (refer to the configuration details on the present power supply section).
		STM32WB5MM-DK is supplied through CN8 directly (refer to the configuration details in the present power supply section).

1. The default configuration is in bold.

When using 5V_USB_STLINK and JP2 [1-2] is ON, the sequence is specific. Only STM32F103 is supplied in the beginning. If the USB enumeration succeeds, the 5V_USB_STLINK power is enabled by asserting the PWR_ENN signal from STM32F103CBT6. This pin is connected to an STMP2141STR power switch, which supplies the rest of the board. This power switch also features a current limitation to protect the PC in case of currents exceeding 300 mA.

7.2.4 Current measurement

As the device handles low-power features, it might be worth measuring the current consumed by the STM32WB5MMG module. To ease this measurement, there are two possibilities:

1. Measure the supply current of the STM32WB5MMG module using an ammeter in place of the JP1 jumper. In this case, all supply sources can be used except the AVDD coming from the ARDUINO® connector. [Figure 9](#) shows the configuration:

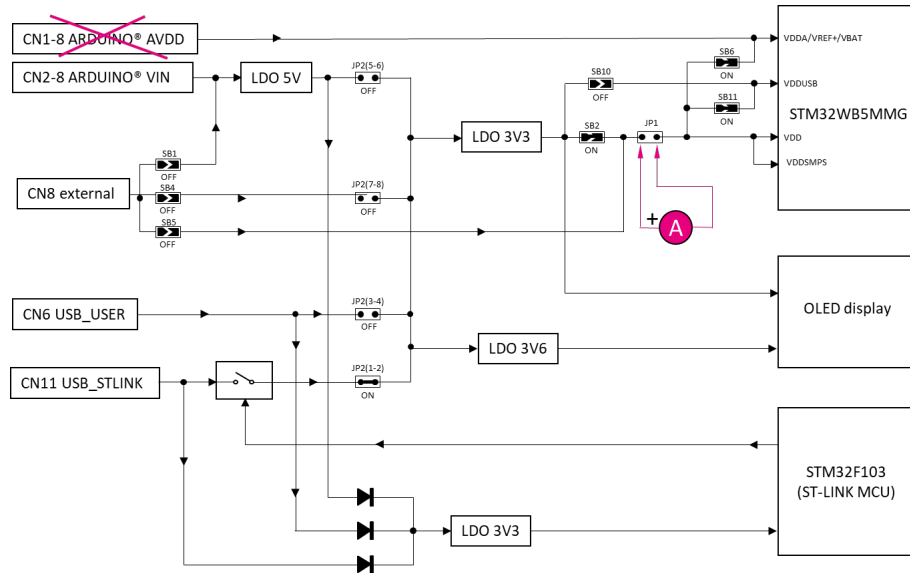
Figure 9. Current measurement with an ammeter

2. Or use an external power supply with current measurement capability. In this case, the JP1 jumper must be removed and the supply connected to pin 2 of JP1. Refer to [Figure 10](#). The supply voltage must be 3.3 V and the AVDD input (CN1-8) must not be used during this measurement.

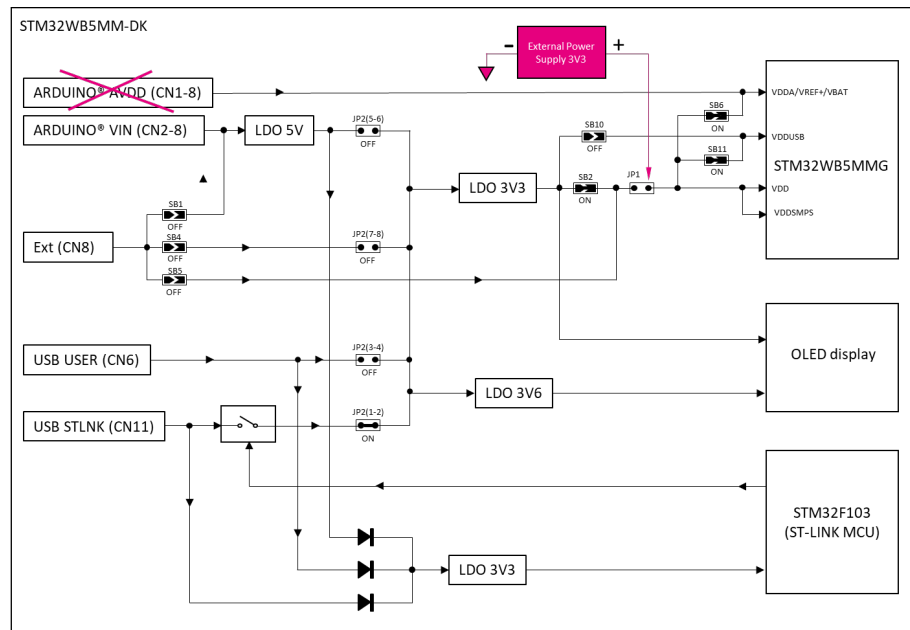
Figure 10. Current measurement with an external power supply

7.3 Clock sources

7.3.1 HSE clock reference

The high-speed clock (HSE) of the STM32WB5MM-DK Discovery kit is embedded in the STM32WB5MMG module. It uses a 32 MHz crystal oscillator. The HSE oscillator is trimmed during module manufacturing.

7.3.2 LSE clock reference

The low-speed clock (LSE) of the STM32WB5MM-DK Discovery kit is embedded in the STM32WB5MMG module. It uses a 32.768 kHz crystal oscillator.

7.4 Reset sources

The reset signal of STM32WB5MMG is active LOW. The internal pull-up resistor forces the RST signal to a HIGH level.

The sources of reset are the following:

- Reset push-button small black button (B3)
- Embedded ST-LINK/V2-1
- ARDUINO® connector (CN2-3), reset from the ARDUINO® board
- TAG10 Tag-Connect™ connector (CN7-10)

7.5 Board functions

7.5.1 128 × 64-pixel OLED display

The STM32WB5MM-DK board embeds an OLED display. It is a 128 × 64-pixel OLED display panel matrix, with high contrast and an SPI-driven interface to display messages and user menus. An embedded controller inside the display manages the OLED panel matrix.

7.5.2 Quad-SPI NOR flash memory (U8)

The STM32WB5MM-DK board embeds a 128-Mbit Quad-SPI NOR flash memory device (S25FL128SDSMFV001 from Cypress), which is connected to an STM32WB5MMG dedicated Quad-SPI interface described in [Table 5](#).

Table 5. Quad-SPI NOR flash memory (U8) connection with STM32WB5MMG

Quad-SPI memory pin number	Quad-SPI memory pin name	STM32WB5MMG pin number	STM32WB5MMG signal name
7	/CS	70 (PD3)	QSPI_BK_NCS
16	SCK	56 (PA3)	QSPI_BK_SCK
15	IO0	11 (PB9)	QSPI_BK_IO0
8	IO1	80 (PD5)	QSPI_BK_IO1
9	IO2	81 (PD6)	QSPI_BK_IO2
1	IO3	67 (PD7)	QSPI_BK_IO3

7.5.3 Virtual COM port

ST-LINK/V2-1 offers a USB Virtual COM port bridge. This feature allows access to the STM32WB5MMG USART1 by the USB_STLINK connector (CN11).

By default, this STM32WB5MMG USART1 interface is connected to the UART2 port of the STM32F103 ST-LINK/V2-1 MCU.

Table 6. UART interface pinout description

STM32WB5MMG	CN10	STM32F103
USART1 Rx (PB7/pin 18)	Pin 1	STLINK_TX: UART2 Tx (PA2/pin 12)
USART1 Tx (PB6/pin 39)	Pin 2	STLINK_RX: UART2 Rx (PA3/pin 13)

7.5.4 MEMS microphone

A MEMS microphone is connected through an SAI interface to the STM32WB5MMG module. SAI1_CK2 and SAI1_DI2 are connected to the microphone and ensure the recording.

Table 7. MEMS-STM32WB5MMG SAI interface

STM32WB5MMG	MEMS
SAI1_CK2 (PA8/pin 50)	CLK, clock in (pin 3)
SAI1_DI2 (PA9/pin 51)	DOUT, PDM data out (pin 4)

7.5.5 LEDs
Description

Five LEDs on the top side of the STM32WB5MM-DK board help the user during the application development.

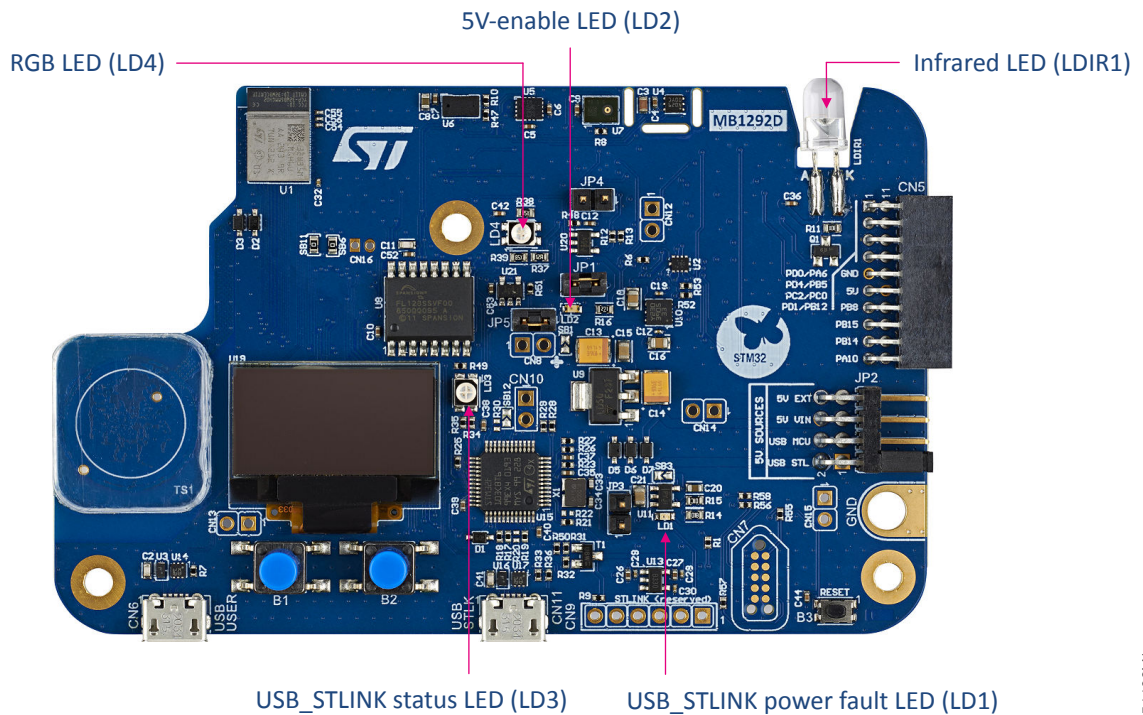
Figure 11. LEDs location

DT54498V1

- LD1: This red LED indicates that the current distribution could not be performed as expected.
- LD2: This LED turns green when the 5 V is available. Refer to [Section 7.2.3](#) to select the 5 V source.
- LD3 COM: LD3 is a bicolor LED, which default status is red, which turns to green to indicate that communication is in progress between the PC and the ST-LINK/V2-1, as follows:
 - Slow blinking red/OFF: At power-on, before USB initialization
 - Fast blinking red/OFF: After the first correct communication between PC and ST-LINK/V2-1 (enumeration)
 - Red ON: When initialization between PC and ST-LINK/V2-1 is successfully finished
 - Green ON: After successful target communication initialization
 - Blinking red/green: During communication with the target
 - Green ON: Communication finished and OK
 - Orange ON: Communication failure
- LD4: This LED is an RGB LED. It is available for the user application.
- LDIR1: This LED allows the transmission of an infrared radiation signal.

RGB LED

The resources coming from STM32WB5MMG are shared between the RGB and IR LEDs. It is not possible to use them simultaneously. The selection is done by JP4 and JP5 jumpers.

To use the RGB LED, JP5 must be ON and JP4 OFF. In this configuration, GPIO_SELECT2 (PH1) is the chip select for this RGB device on SPI1.

The RGB LED is driven by the TLC59731 PWM LED driver from Texas Instruments.

Infrared (IR) LED

The resources coming from STM32WB5MMG are shared between the RGB and IR LEDs. It is not possible to use them simultaneously. The selection is done by JP4 and JP5 jumpers.

To use the IR LED, JP4 must be ON and JP5 OFF. In this configuration, GPIO_SELECT2 (PH1) is the chip select for this IR transmission. PB9 is in charge of the IR modulation. This GPIO is shared with the Quad-SPI flash memory. It is possible to use the flash memory and IR LED on the same application but not exactly at the same time.

The TIM16 and TIM17 internal timers drive the IR LED. The schematic proposal does not use the IR_OUT feature. A firmware example is available in the firmware package.

7.5.6 Push-buttons

Description

The STM32WB5MM-DK Discovery kit provides three buttons:

- User push-button (B1)
- User push-button (B2)
- Reset push-button (B3), used to reset STM32WB5MM-DK Discovery kit.

Reset push-button

B3 is a small push-button dedicated to the hardware reset of the STM32WB5MM-DK. It is separated from the other push-buttons to avoid mishandling.

User push-buttons

There are two push-buttons available for the user application. They are connected to PC12 and PC13. It is possible to use them for GPIO reading or to wake up the device.

Table 8. Physical user interface I/O configuration (push-buttons)

Name	I/O	Available wake-up
User1 push-button (B1)	PC12	WKUP3
User2 push-button (B2)	PC13	WKUP2

7.5.7 Touch sensor

The STM32WB5MM-DK board embeds a touch sensor. The touch sensor works with the charge and discharge of a capacitor. Touching the round panel with a finger charges a capacitor. Once the capacitor is charged at VDD, the charge is transferred to another capacitor, called the sampling capacitor.

Two groups of I/Os are connected to use it:

Table 9. Physical user interface I/O configuration (touch sensor)

I/O group	I/O	Configuration
Shield group 4	PC6	TSC_G4_IO1
	PC7	TSC_G4_IO2
Touchkey group 6	PD10	TSC_G6_IO1
	PD11	TSC_G6_IO2

7.6 Embedded sensors

7.6.1 I²C interface

The STM32WB5MM-DK embedded sensors are connected to the STM32WB5MMG module with an I²C bus. The Time-of-Flight (ToF), accelerometer/gyroscope, and temperature sensors are connected to the STM32WB5MMG I2C3 bus.

Table 10. STM32WB5MMG I²C

STM32WB5MMG port	Description
PB13 (pin 35)	I2C3_SCL
PB11 (pin 46)	I2C3_SDA

The address is a 7-bit address with an additional R/W bit (HIGH for reading, LOW for writing). [Table 11](#) describes the different address to R/W action for each component:

Table 11. Sensor I²C addresses

Device	Action	Address
Accelerometer-gyroscope sensor	Read	0b11010111 (D7h)
	Write	0b11010110 (D6h)
Temperature sensor	Read	0b01110001 (71h)
	Write	0b01110000 (70h)
Time-of-Flight sensor	Read	0b01010011 (53h)
	Write	0b01010010 (52h)

7.6.2 Time-of-Flight (ToF) sensor (U6)

U6 is a device that allows measuring the Time-of-Flight (ToF) of a laser beam. It is connected to the STM32WB5MMG through the I²C interface.

This sensor can make a distance measurement and obstacle detection of two meters and 1D-gesture recognition.

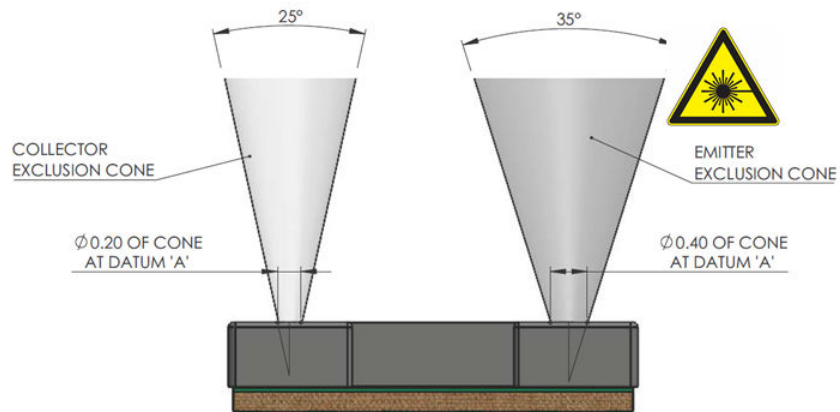
Figure 12. Direction, angle, and side operating

Top side
MB1292B
Bottom side
Table 12. Time-of-Flight sensor (U6) I²C address

Device	Action	Address
Time-of-Flight sensor	Read	0b01010011 (53h)
	Write	0b01010010 (52h)

7.6.3 3D accelerometer and 3D gyroscope sensor (U5)

U5 is connected to STM32WB5MMG through the I²C interface.

U5 is a system-in-package featuring a high-performance 3D digital accelerometer and 3D digital gyroscope tailored for Industry 4.0 applications.

Figure 13. 3D direction for acceleration and angular rate

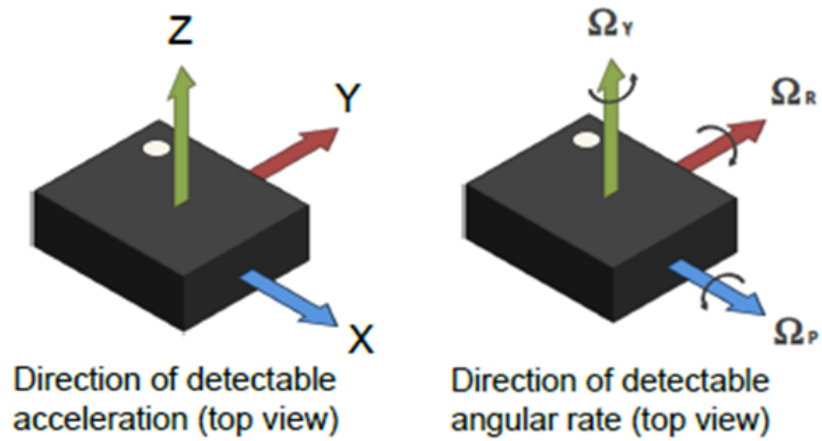
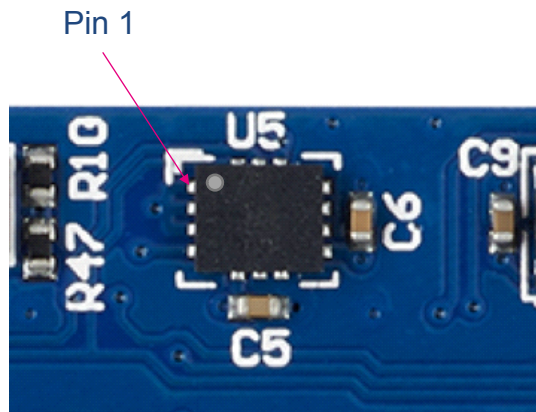

Figure 14. 3D accelerometer and 3D gyroscope (U5) pin 1 location



DT54497V1

Table 13. Accelerator-gyroscope sensor (U5) I²C address

Device	Action	Address
Accelerator-gyroscope sensor	Read	0b11010111 (D7h)
	Write	0b11010110 (D6h)

7.6.4 Temperature sensor (U4)

U4 is a device that measures ambient temperature. It is connected to the STM32WB5MMG through the I²C interface.

Table 14. Temperature sensor (U4) I²C address

Device	Action	Address
Temperature sensor	Read	0b01110001 (71h)
	Write	0b01110000 (70h)

8 Board connectors

The following connectors are implemented on the STM32WB5MM-DK board and described in the next subsections:

- ST-LINK/V2-1 USB Micro-B connector (CN11)
- USB FS Micro-B connector (CN6)
- STMod+ connector (CN5)
- TAG10 Tag-Connect™ footprint (CN7)
- ARDUINO® Uno V3 connector (CN1, CN2, CN3, and CN4)

8.1 ST-LINK/V2-1 USB Micro-B connector (CN11)

The main function of this connector is to connect the STM32WB5MM-DK embedded ST-LINK/V2-1 to the PC for programming and debugging purposes. It can supply the board (refer to [Section 7.2: Power supply](#)).

The connector is a standard USB Micro-B connector.

The related pinout for the ST-LINK USB Micro-B connector (CN11) is listed in [Table 15](#).

Table 15. USB Micro-B connector (CN11) pinout

Pin number	Pin name	Signal name	Function
1	VBUS	5V_USB_ST_LINK	V _{BUS} power
2	DM	USB_STLK_N	DM
3	DP	USB_STLK_P	DP
4	ID	-	-
5	GND	GND	Ground

8.2 USB FS Micro-B connector (CN6)

The STM32WB5MMG module handles a USB full-speed peripheral, available on the USB Micro-B connector (CN6). It can communicate with a USB host as a USB device and can supply the board. Refer to [Section 7.2](#) for more details.

The related pinout of the USB Micro-B connector (CN6) is listed in [Table 16](#).

Table 16. USB Micro-B connector (CN6) pinout

Pin number	Pin name	Signal name	Function
1	VBUS	5V_USB_MCU	V _{BUS} power
2	DM	USB_N	DM
3	DP	USB_P	DP
4	ID	-	-
5	GND	GND	Ground

8.3 STMod+ connector (CN5)

The STMod+ standard connector (CN5) is on the STM32WB5MM-DK board to support flexibility in a small form factor application.

Figure 15 shows the pinout of the STMod+ connector.

Caution: Check the orientation before plugging the fanout or expansion board. An error in orientation can generate important damage to the STM32WB5MM-DK main board and the daughterboard.

Figure 15. STMod+ connector (CN5)

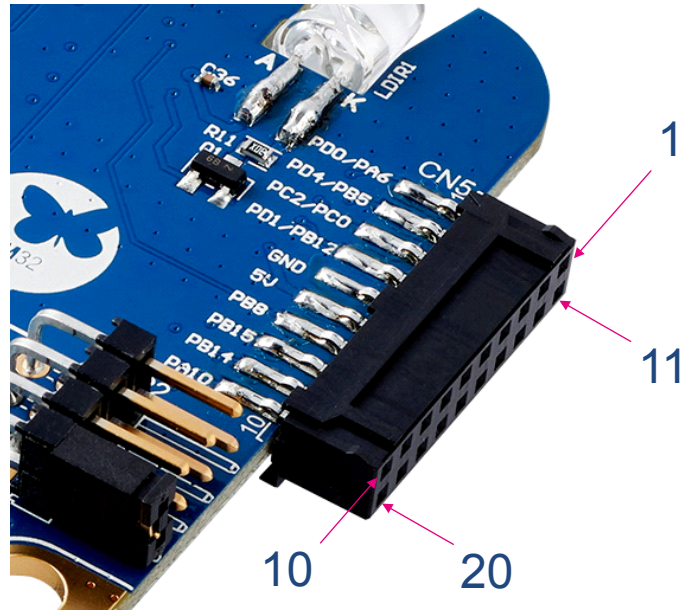

Figure 16. Top silkscreen STMod+ connector

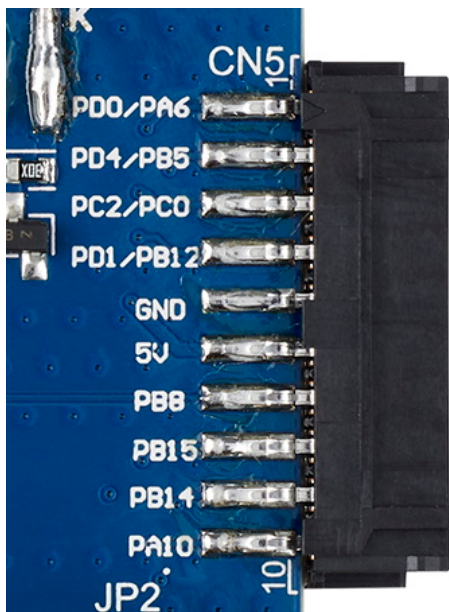
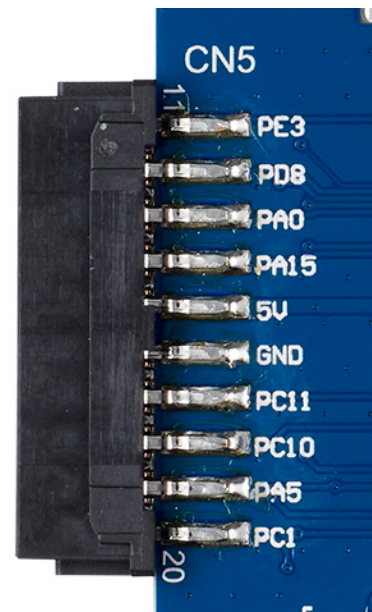

Figure 17. Bottom silkscreen STMod+ connector



DT55001V1

Table 17. STMod+ connector (CN5) pinout

Pin number	STM32WB5MMG pin	Function
1	PD0	SPI2_NSS
	PA6	LPUART1_CTS
2	PD4	SPI2_MOSI (1)
	PB5	LPUART1_TXD
3	PC2	SPI2_MISO (1)
	PC0	LPUART1_RXD
4	PD1	SPI2_SCK
	PB12	LPUART1_RTS
5	GND	Ground
6	+5 V	Power
7	PB8	I2C1_SCL
8	PB15	SPI2_MOSI (2)
9	PB14	SPI2_MISO (2)
10	PA10	I2C1_SDA
11	PE3	INT
12	PD8	STMOD+_RESET
13	PA0	ADC1_IN5
14	PA15	PWM (TIM2_CH1)
15	+5 V	Power
16	GND	Ground
17	PC11	GPIO
18	PC10	GPIO
19	PA5	GPIO
		ADC1_IN10
20	PC1	GPIO
		ADC1_IN12

8.4 TAG10 Tag-Connect™ footprint (CN7)

Section 7.1 presents the ST-LINK default debugging and programming tool. However, it is possible to use another debugging and programming tool through the Tag-Connect™ in its TAG10 10-pin version.

Figure 18. Tag-Connect™ footprint (CN7) pinout

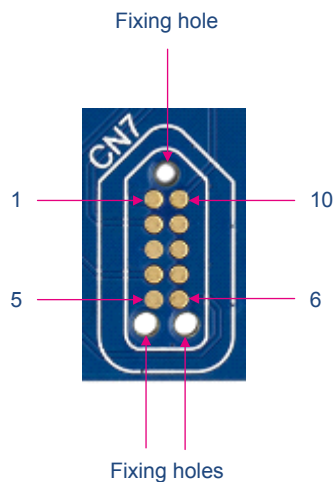

DT54494V1

Table 18. TAG10 Tag-Connect™ footprint (CN7) pinout

Pin number	Pin name	Signal name	STM32WB5MMG pin	Function
1	3V3_STLK	3V3	-	Reference level
2	TAG_SWDIO	SWDIO	PA13	Serial wire data I/O
3	GND	-	-	Ground
4	TAG_SWCLK	SWCLK	PA14	Serial wire clock
5	GND	-	-	Ground
6	TAG_SWO	SWO	PB3	Serial wire output
7	NC	-	-	-
8	NC	-	-	-
9	NC	-	-	-
10	TAG_NRST	/Reset	NRST	Reset

If Tag-Connect™ is used, it is very important to disable the embedded ST-LINK to avoid signal conflict between this ST-LINK and the external tool. To disable the embedded ST-LINK, it is only necessary to set the STM32F103 in reset mode, with the JP3 jumper ON.

To benefit from this connection, it is necessary to use the TC2050-IDC-NL accessory cable shown in Figure 19.

Figure 19. TC2050-IDC-NL cable

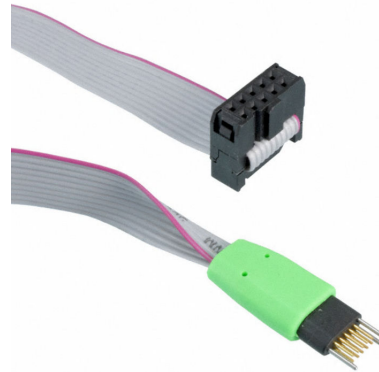

8.5 ARDUINO® Uno V3 connector (CN1, CN2, CN3, and CN4)

8.5.1 Description

ARDUINO® Uno V3 extension socket is located on the bottom side of the board. It is built around CN1, CN2, CN3, and CN4 standard connectors. Most shields designed for ARDUINO® can fit with Discovery kits to offer flexibility in small form factor applications.

Figure 20. ARDUINO® Uno connectors and ARDUINO® shield location

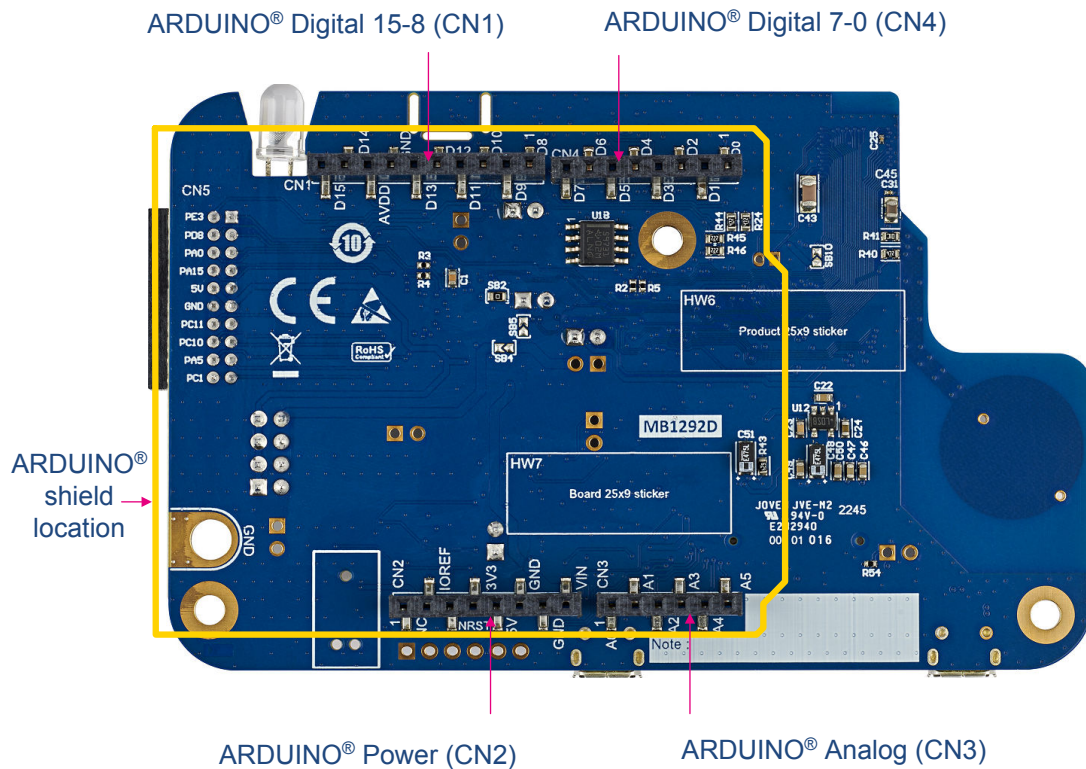

DT54499V1

8.5.2 ARDUINO® operating voltage

The ARDUINO® Uno V3 connector supports 5 V, 3.3 V, and VDD for I/O compatibility.

Warning: Do not supply 3.3 V or 5 V from the ARDUINO® shield. Supplying 3.3 V or 5 V from the ARDUINO® shield could damage the STM32WB5MM-DK Discovery kit.

Furthermore, if it is necessary to supply the STM32WB5MM-DK board with the ARDUINO® connector, the VIN dedicated pin is available to supply the board directly. For more information on this feature, refer to Section 7.2.2: 7 to 12 V power supply.

8.5.3 ARDUINO® interface and pinout

Figure 21 shows the position of the ARDUINO® shield when it is plugged into STM32WB5MM-DK with the pinout. The pinout shown in this figure corresponds to standard ARDUINO® naming. To find the correspondence with the STM32, refer to Table 19.

Figure 21. ARDUINO® pinout location

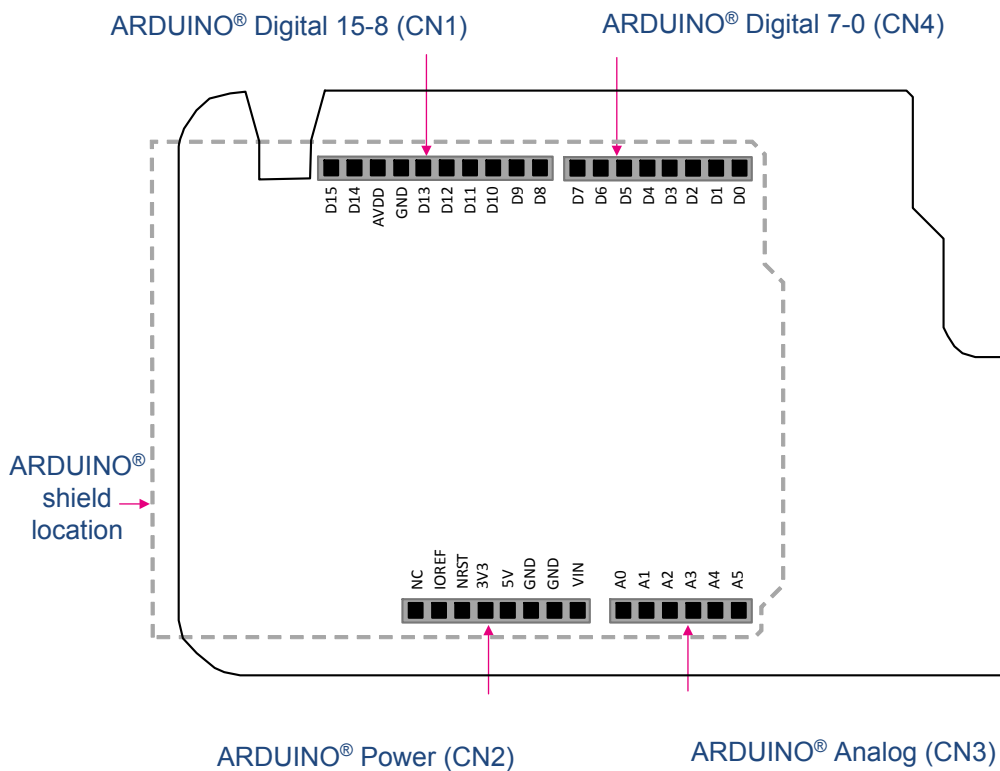

DT55000V1

Table 19. ARDUINO® connector pinout

Left connectors					Right connectors				
Connector	Pin number	Pin name	MCU pin	Function	Function	MCU pin	Pin name	Pin number	Connector
CN2 Power	1	NC	-	NC (reserved for the test)	I2C1_SCL	PB8	ARD_D15	10	CN1 Digital
	2	3V3 (IOREF)	-	IOREF 3V3	I2C1_SDA	PA10	ARD_D14	9	
	3	NRST	NRST	NRST	VDDA	-	AVDD	8	
	4	3V3	-	3.3 V	Ground	-	GND	7	
	5	5V	-	5 V	SPI1_SCK	PA1	ARD_D13	6	
	6	GND	-	Ground	SPI1_MISO	PB4	ARD_D12	5	
	7	GND	-	Ground	SPI1_MOSI/ TIM17_CH1	PA7	ARD_D11	4	
	8	VIN	-	External supply input (+12 V)	SPI1_NSS	PA4	ARD_D10	3	
CN3 Analog	1	A0	PC3	ADC1_IN4	GPIO/ TIM1_CH2	PD15	ARD_D9	2	CN4 Digital
	2	A1	PA2	ADC1_IN7	GPIO	PD13	ARD_D8	1	
	3	A2	PA5	ADC1_IN10	GPIO	PB2	ARD_D7	8	
	4	A3	PC1	ADC1_IN2	GPIO/ TIM16_CH1	PE0	ARD_D6	7	
	5	A4	PC4	ADC1_IN13	GPIO/ TIM2_CH3	PB10	ARD_D5	6	
	6	A5	PC5	ADC1_IN14	GPIO	PE3	ARD_D4	5	
				GPIO/ TIM1_CH1	PD14	ARD_D3	4		
				GPIO	PD12	ARD_D2	3		
				LPUART1_TX	PB5	ARD_D1	2		
				LPUART1_RX	PC0	ARD_D0	1		



9 STM32WB5MM-DK I/O assignment

Table 20. STM32WB5MM-DK I/O assignment

Pin number	Pin name	Assignment on STM32WB5MM-DK
1	PA2	ADC1_IN7 (ARDUINO® A1)
2	PA1	SPI1_SCK (ARDUINO® D13)
3	PA0	ADC1_IN5 (STMod+ pin 13)
7	PC3	ADC1_IN4 (ARDUINO® A0)
8	PC2	SPI2_MISO (STMod+ pin 3)
9	PC1	ADC1_IN2 (STMod+ pin 20 and ARDUINO® A3)
11	PB9	QUADSPI_BK1_IO0 or IR LED control
12	PC0	LPUART1_RX (STMod+ pin 3 and ARDUINO® D0)
13	PH3-BOOT0	BOOT0 (Pull-down by default, connected to CN13)
14	PB8	I2C1_SCL (STMod+ pin 7 and ARDUINO® D15)
18	PB7	USART1_RX (VCP ST-LINK)
19	PB5	LPUART1_TX (STMod+ on pin 2 and ARDUINO® D1)
20	PB4	SPI1_MISO (SPI OLED display, ARDUINO® D11)
21	PB3	SWO (ST-LINK)
22	PC10	GPIO (STMod+ pin18)
23	PC11	GPIO (STMod+ pin 17)
24	PC12	User push-button B1 (WKUP3)
25	PA13	SWDIO (ST-LINK)
26	PA14	SWCLK (ST-LINK)
27	PA15	TIM2_CH1/PWM (STMod+ pin 14)
28	PA10	I2C1_SDA (STMod+ pin 10 and ARDUINO® D14)
29	PA12	USB_DP
30	PA11	USB_DM
33	PD0	SPI2_NSS (STMod+ pin 1)
34	PD1	SPI2_SCK (STMod+ pin 4)
35	PB13	I2C3_SCL (MEMS sensors)
36	PC6	TSC_G4_IO1 (Touchkey)
37	PB14	SPI2_MISO (STMod+ pin 9)
38	PB15	SPI2_MOSI (STMod+ pin 8)
39	PB6	USART1_TX (VCP ST-LINK)
40	PC13	User push-button B2 (WKUP2)
41	PB12	LPUART1_RTS (STMod+ pin 4)
42	PE4	GPIO (ARDUINO® D4)
45	PC5	ADC1_IN14 (ARDUINO® A5)
46	PB11	I2C3_SDA (MEMS sensors)
47	PB10	TIM2_CH3 (ARDUINO® D5)
48	PB2	GPIO (ARDUINO® D7)

Pin number	Pin name	Assignment on STM32WB5MM-DK
49	PC4	ADC1_IN13 (ARDUINO® A4)
50	PA8	SAI1_CK2 (Digital microphone)
51	PA9	SAI1_DI2 (Digital microphone)
52	PA7	SPI1_MOSI (SPI OLED display/ARDUINO® D1/RGB LED driver) *
53	PA6	LPUART_CTS (STMod+ pin 1)
54	PA5	ADC1_IN10 (STMod+ pin 19 and ARDUINO® D10)
55	PA4	SPI1_NSS (ARDUINO® D10)
56	PA3	QUADSPI_SCLK (Quad-SPI flash memory)
61	PH0	SPI1_NSS (SPI chip select of OLED display)
62	PH1	GPIO_SELECT2 (RGB LED/Infrared LED)
63	PD14	TIM_CH1 (ARDUINO® D3)
64	PE1	DRDY (Temperature sensor)
65	PD13	GPIO (ARDUINO® D8)
66	PD12	GPIO (ARDUINO® D2)
67	PD7	QUADSPI_BK1_IO3 (Quad-SPI flash memory)
68	PD2	INT signal for accelerometer-gyroscope sensor
69	PC9	D/C_DISP (data or ctrl OLED display)
70	PD3	QUADSPI_BK1_NCS (Quad-SPI flash memory)
71	PC7	TSC_G4_IO2 (Touchkey)
72	PE3	INT STMod+ (STMod+ pin 11)
73	PD4	SPI2_MOSI (STMod+ pin2)
74	PD9	INT signal for Time-of-Flight sensor
75	PD8	STMod+ RESET (STMod+ pin 12)
76	PD15	TIM1_CH2 (ARDUINO® D9)
77	PD10	TSC_G6_IO1 (Touchkey)
78	PE2	GPIO_SELECT1 (Ctrl switch LPUART)
79	PE0	TIM16_CH1 (ARDUINO® D6)
80	PD5	QUADSPI_BK1_IO1 (Quad-SPI flash memory)
81	PD6	QUADSPI_BK1_IO2 (Quad-SPI flash memory)
82	PD11	TSC_G6_IO2 (Touchkey)
83	PC8	RST_DISP (OLED display reset)

10 STM32WB5MM-DK product information

10.1 Product marking

The stickers located on the top or bottom side of all PCBs provide product information:

- First sticker: product order code and product identification, generally placed on the main board featuring the target device.

Example:

Product order code Product identification
--

- Second sticker: board reference with revision and serial number, available on each PCB.

Example:

MBxxxx-Variant-yzz syywwxxxxx	
----------------------------------	---

On the first sticker, the first line provides the product order code, and the second line the product identification.

On the second sticker, the first line has the following format: “*MBxxxx-Variant-yzz*”, where “*MBxxxx*” is the board reference, “*Variant*” (optional) identifies the mounting variant when several exist, “*y*” is the PCB revision, and “*zz*” is the assembly revision, for example B01. The second line shows the board serial number used for traceability.

Parts marked as “*ES*” or “*E*” are not yet qualified and therefore not approved for use in production. ST is not responsible for any consequences resulting from such use. In no event will ST be liable for the customer using any of these engineering samples in production. ST’s Quality department must be contacted prior to any decision to use these engineering samples to run a qualification activity.

“*ES*” or “*E*” marking examples of location:

- On the targeted STM32 that is soldered on the board (for an illustration of STM32 marking, refer to the STM32 datasheet *Package information* paragraph at the www.st.com website).
- Next to the evaluation tool ordering part number that is stuck, or silk-screen printed on the board.

Some boards feature a specific STM32 device version, which allows the operation of any bundled commercial stack/library available. This STM32 device shows a “*U*” marking option at the end of the standard part number and is not available for sales.

To use the same commercial stack in their applications, the developers might need to purchase a part number specific to this stack/library. The price of those part numbers includes the stack/library royalties.

10.2 STM32WB5MM-DK product history

Table 21. Product history

Order code	Product identification	Product details	Product change description	Product limitations
STM32WB5MM-DK	DK32WB5MM\$GU1	Module:	Initial revision	PB0/PB1 not available
		<ul style="list-style-type: none"> STM32WB5MMG silicon revision "Y" 		
		MCU errata sheet:		
	DK32WB5MM\$GU2	<ul style="list-style-type: none"> STM32WB5MMG module product errata (ES0525) 	Main board revision changed	No limitation
		Board:		
		<ul style="list-style-type: none"> MB1292-WB5MM-B01 (main board) 		
	DK32WB5MM\$GU3	MCU:	Obtained SRRC certification	No limitation
		<ul style="list-style-type: none"> STM32WB5MMG silicon revision "X" 		
		MCU errata sheet:		
DK32WB5MM\$GU3	<ul style="list-style-type: none"> STM32WB5MMG module product errata (ES0525) 			
	Board:			
	<ul style="list-style-type: none"> MB1292-WB5MM-D01 (main board) 			

10.3 Board revision history

Table 22. Board revision history

Board reference	Board variant and revision	Board change description	Board limitations
MB1292 (main board)	WB5MM-B01	Initial revision	PB0/PB1 not available
	WB5MM-D01	<ul style="list-style-type: none"> Component reference updates due to obsolescence issues: LD3 LED and HW1 shunt Added to the BOM item list: M1 plexiglass touchkey and TA1 double-stick tape 	No limitation

11 Federal Communications Commission (FCC) and ISED Canada Compliance Statements

11.1 FCC Compliance Statement

Identification of products: STM32WB5MM-DK.

Contains certified module from STMicroelectronics: STM32WB5MMG

FCC ID: YCP-32WB5MMGH02

Part 15.19

This device complies with Part 15 of the FCC Rules. Operation is subject to the following two conditions: (1) this device may not cause harmful interference, and (2) this device must accept any interference received, including interference that may cause undesired operation.

Part 15.21

Any changes or modifications to this equipment not expressly approved by STMicroelectronics may cause harmful interference and void the user's authority to operate this equipment.

Part 15.105

This equipment has been tested and found to comply with the limits for a Class B digital device, pursuant to part 15 of the FCC Rules. These limits are designed to provide reasonable protection against harmful interference in a residential installation. This equipment generates uses and can radiate radio frequency energy and, if not installed and used in accordance with the instruction, may cause harmful interference to radio communications. However, there is no guarantee that interference will not occur in a particular installation. If this equipment does cause harmful interference to radio or television reception which can be determined by turning the equipment off and on, the user is encouraged to try to correct interference by one or more of the following measures:

- Reorient or relocate the receiving antenna.
- Increase the separation between the equipment and receiver.
- Connect the equipment into an outlet on a circuit different from that to which the receiver is connected.
- Consult the dealer or an experienced radio/TV technician for help.

Note: Use only shielded cables.

To satisfy FCC RF exposure requirements, a separation distance of 20 cm or more should be maintained between the antenna of this device and persons during operation. To ensure compliance, operation at a closer distance than this is not recommended. This transmitter must not be collocated or operating in conjunction with any other antenna or transmitter.

Responsible party (in the USA)

Francesco Doddo
STMicroelectronics, Inc.
200 Summit Drive | Suite 405 | Burlington, MA 01803
USA
Telephone: +1 781-472-9634

11.2 ISED Compliance Statement

This radio transmitter (8976A-32WB5MMGH02) has been approved by ISED Canada to operate with the antenna types listed below with the maximum permissible gain and required antenna impedance for each antenna type indicated. Antenna types not included in this list, having a gain greater than the maximum gain indicated for that type, are strictly prohibited for use with this device.

Le présent émetteur radio (8976A-32WB5MMGH02) a été approuvé par ISED Canada pour fonctionner avec les types d'antenne énumérés ci-dessous et ayant un gain admissible maximal et l'impédance requise pour chaque type d'antenne. Les types d'antenne non inclus dans cette liste, ou dont le gain est supérieur au gain maximal indiqué, sont strictement interdits pour l'exploitation de l'émetteur.

Compliance Statement

Notice: This device complies with ISED Canada licence-exempt RSS standard(s). Operation is subject to the following two conditions: (1) this device may not cause interference, and (2) this device must accept any interference, including interference that may cause undesired operation of the device.

ISED Canada ICES-003 Compliance Label: CAN ICES-3 (B) / NMB-3 (B).

Déclaration de conformité

Avis: Le présent appareil est conforme aux CNR d'ISDE Canada applicables aux appareils radio exempts de licence. L'exploitation est autorisée aux deux conditions suivantes : (1) l'appareil ne doit pas produire de brouillage, et (2) l'utilisateur de l'appareil doit accepter tout brouillage radioélectrique subi, même si le brouillage est susceptible d'en compromettre le fonctionnement.

Étiquette de conformité à la NMB-003 d'ISDE Canada : CAN ICES-3 (B) / NMB-3 (B).

RF exposure statement

This device complies with ISED radiation exposure limits set forth for general population. This device must be installed to provide a separation distance of at least 20 centimeters from all persons and must not be co-located or operating in conjunction with any other antenna or transmitter.

Le présent appareil est conforme aux niveaux limites d'exigences d'exposition RF aux personnes définies par ISDE. L'appareil doit être installé afin d'offrir une distance de séparation d'au moins 20 centimètres avec les personnes et ne doit pas être installé à proximité ou être utilisé en conjonction avec une autre antenne ou un autre émetteur.

12 Radio Equipment Directive (RED) compliance statement

Déclaration de conformité CE simplifiée :

STMicroelectronics déclare que l'équipement radioélectrique du type STM32WB5MM-DK est conforme à la directive 2014/53/UE.

Bande de fréquence utilisée en transmission et puissance maximale rayonnée dans cette bande :

- Bande de fréquence : 2400-2483.5 MHz (Bluetooth®)
- Puissance maximale : 4 mW p.i.r.e

Simplified EC compliance statement:

Hereby, STMicroelectronics declares that the radio equipment type STM32WB5MM-DK is in compliance with Directive 2014/53/EU.

Frequency range used in transmission and maximal radiated power in this range:

- Frequency range: 2400-2483.5 MHz (Bluetooth®)
- Maximal power: 4 mW e.i.r.p

13 Declaration of 2.4GHz IEEE 802.15.4 Compliance with Micropower Device Regulations

2.4GHz IEEE 802.15.4符合微功率设备法规声明:

- (一) 符合“微功率短距离无线电发射设备目录和技术要求”的具体条款和使用场景，采用的天线类型和性能，控制、调整及开关等使用方法；
- (二) 不得擅自改变使用场景或使用条件、扩大发射频率范围、加大发射功率（包括额外加装射频功率放大器），不得擅自更改发射天线；
- (三) 不得对其他合法的无线电台（站）产生有害干扰，也不得提出免受有害干扰保护；
- (四) 应当承受辐射射频能量的工业、科学及医疗（ISM）应用设备的干扰或其他合法的无线电台（站）干扰；
- (五) 如对其他合法的无线电台（站）产生有害干扰时，应立即停止使用，并采取措施消除干扰后方可继续使用；
- (六) 在航空器内和依据法律法规、国家有关规定、标准划设的射电天文台、气象雷达站、卫星地球站（含测控、测距、接收、导航站）等军民用无线电台（站）、机场等的电磁环境保护区域内使用微功率设备，应当遵守电磁环境保护及相关行业主管部门的规定；
- (七) 禁止在以机场跑道中心点为圆心、半径5000米的区域内使用各类模型遥控器；
- (八) 微功率设备使用时温度和电压的环境条件。

Revision history

Table 23. Document revision history

Date	Revision	Changes
23-Apr-2021	1	Initial release.
09-Nov-2023	2	<p>Document reshuffled to align with the latest standards, from <i>Introduction</i> to <i>Section 12: Radio Equipment Directive (RED) compliance statement</i>.</p> <p>Updated:</p> <ul style="list-style-type: none"> • <i>Figure 1, Figure 4, Figure 5, Figure 11, and Figure 20</i> board version • <i>STM32WB5MM-DK</i> product information including new <i>Product history</i> and <i>Board revision history</i> tables • <i>Federal Communications Commission (FCC) and ISED Canada Compliance Statements</i> with FCC ID and radio transmitter reference <p>Added <i>Declaration of 2.4GHz IEEE 802.15.4 Compliance with Micropower Device Regulations</i>.</p>
10-Jul-2024	3	Updated Product history and Board revision history tables with the third main board revision.

Contents

1	Features	2
2	Ordering information	3
2.1	Codification	3
3	Development environment	4
3.1	System requirements	4
3.2	Development toolchains	4
3.3	Demonstration software	4
4	Conventions	5
5	Safety recommendations	6
5.1	Targeted audience	6
5.2	Handling the board	6
5.3	Laser safety consideration	6
6	Getting started	7
7	Hardware layout and configuration	8
7.1	Embedded ST-LINK/V2-1	11
7.1.1	Drivers	11
7.1.2	ST-LINK/V2-1 firmware upgrade	11
7.2	Power supply	12
7.2.1	General description	12
7.2.2	7 to 12 V power supply	12
7.2.3	5 V power supply	13
7.2.4	Current measurement	14
7.3	Clock sources	15
7.3.1	HSE clock reference	15
7.3.2	LSE clock reference	15
7.4	Reset sources	15
7.5	Board functions	16
7.5.1	128 × 64-pixel OLED display	16
7.5.2	Quad-SPI NOR flash memory (U8)	16
7.5.3	Virtual COM port	16
7.5.4	MEMS microphone	16
7.5.5	LEDs	17
7.5.6	Push-buttons	18
7.5.7	Touch sensor	18
7.6	Embedded sensors	19

7.6.1	I ² C interface	19
7.6.2	Time-of-Flight (ToF) sensor (U6)	20
7.6.3	3D accelerometer and 3D gyroscope sensor (U5)	21
7.6.4	Temperature sensor (U4)	22
8	Board connectors	23
8.1	ST-LINK/V2-1 USB Micro-B connector (CN11)	23
8.2	USB FS Micro-B connector (CN6)	23
8.3	STMod+ connector (CN5)	24
8.4	TAG10 Tag-Connect™ footprint (CN7)	26
8.5	ARDUINO® Uno V3 connector (CN1, CN2, CN3, and CN4)	27
8.5.1	Description	27
8.5.2	ARDUINO® operating voltage	28
8.5.3	ARDUINO® interface and pinout	28
9	STM32WB5MM-DK I/O assignment	30
10	STM32WB5MM-DK product information	32
10.1	Product marking	32
10.2	STM32WB5MM-DK product history	33
10.3	Board revision history	33
11	Federal Communications Commission (FCC) and ISED Canada Compliance Statements	34
11.1	FCC Compliance Statement	34
11.2	ISED Compliance Statement	35
12	Radio Equipment Directive (RED) compliance statement	36
13	Declaration of 2.4GHz IEEE 802.15.4 Compliance with Micropower Device Regulations	37
	Revision history	38
	List of tables	41
	List of figures	42

List of tables

Table 1.	Ordering information	3
Table 2.	Codification explanation	3
Table 3.	ON/OFF convention	5
Table 4.	JP2 power supply selector description	13
Table 5.	Quad-SPI NOR flash memory (U8) connection with STM32WB5MMG	16
Table 6.	UART interface pinout description	16
Table 7.	MEMS-STM32WB5MMG SAI interface	16
Table 8.	Physical user interface I/O configuration (push-buttons)	18
Table 9.	Physical user interface I/O configuration (touch sensor)	18
Table 10.	STM32WB5MMG I ² C	19
Table 11.	Sensor I ² C addresses	19
Table 12.	Time-of-Flight sensor (U6) I ² C address	20
Table 13.	Accelerator-gyroscope sensor (U5) I ² C address	21
Table 14.	Temperature sensor (U4) I ² C address	22
Table 15.	USB Micro-B connector (CN11) pinout	23
Table 16.	USB Micro-B connector (CN6) pinout	23
Table 17.	STMod+ connector (CN5) pinout	25
Table 18.	TAG10 Tag-Connect™ footprint (CN7) pinout	26
Table 19.	ARDUINO® connector pinout	29
Table 20.	STM32WB5MM-DK I/O assignment	30
Table 21.	Product history	33
Table 22.	Board revision history	33
Table 23.	Document revision history	38

List of figures

Figure 1.	STM32WB5MM-DK Discovery kit	1
Figure 2.	Class 1 laser product label	6
Figure 3.	STM32WB5MM-DK hardware block diagram	8
Figure 4.	STM32WB5MM-DK PCB layout (top view)	9
Figure 5.	STM32WB5MM-DK PCB layout (bottom view)	9
Figure 6.	STM32WB5MM-DK board mechanical dimensions (top view, in millimeters)	10
Figure 7.	USB Composite Device	11
Figure 8.	STM32WB5MM-DK power tree	12
Figure 9.	Current measurement with an ammeter	14
Figure 10.	Current measurement with an external power supply	14
Figure 11.	LEDs location	17
Figure 12.	Direction, angle, and side operating	20
Figure 13.	3D direction for acceleration and angular rate	21
Figure 14.	3D accelerometer and 3D gyroscope (U5) pin 1 location	21
Figure 15.	STMod+ connector (CN5)	24
Figure 16.	Top silkscreen STMod+ connector	24
Figure 17.	Bottom silkscreen STMod+ connector	24
Figure 18.	Tag-Connect™ footprint (CN7) pinout	26
Figure 19.	TC2050-IDC-NL cable	27
Figure 20.	ARDUINO® Uno connectors and ARDUINO® shield location	27
Figure 21.	ARDUINO® pinout location	28

IMPORTANT NOTICE – READ CAREFULLY

STMicroelectronics NV and its subsidiaries (“ST”) reserve the right to make changes, corrections, enhancements, modifications, and improvements to ST products and/or to this document at any time without notice. Purchasers should obtain the latest relevant information on ST products before placing orders. ST products are sold pursuant to ST’s terms and conditions of sale in place at the time of order acknowledgment.

Purchasers are solely responsible for the choice, selection, and use of ST products and ST assumes no liability for application assistance or the design of purchasers’ products.

No license, express or implied, to any intellectual property right is granted by ST herein.

Resale of ST products with provisions different from the information set forth herein shall void any warranty granted by ST for such product.

ST and the ST logo are trademarks of ST. For additional information about ST trademarks, refer to www.st.com/trademarks. All other product or service names are the property of their respective owners.

Information in this document supersedes and replaces information previously supplied in any prior versions of this document.

© 2024 STMicroelectronics – All rights reserved